

THESE DRAWINGS ARE THE PROPERTY OF QUALTEK ELECTRONICS AND NOT TO BE REPRODUCED FOR OR COMMUNICATED TO A THIRD PARTY WITHOUT THE EXPRESS WRITTEN PERMISSION OF AN OFFICER OF QUALTEK ELECTRONICS.

REVISION			
REV.	DESCRIPTION	DATE	APPROVED

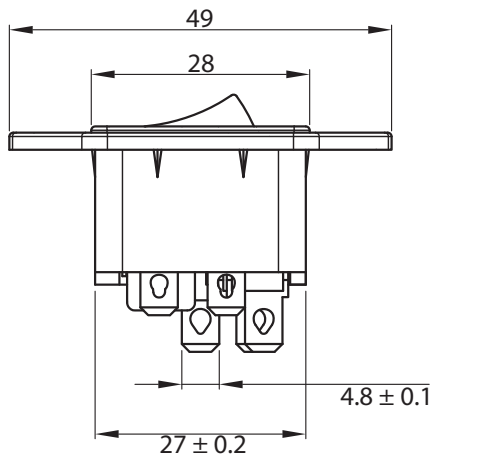
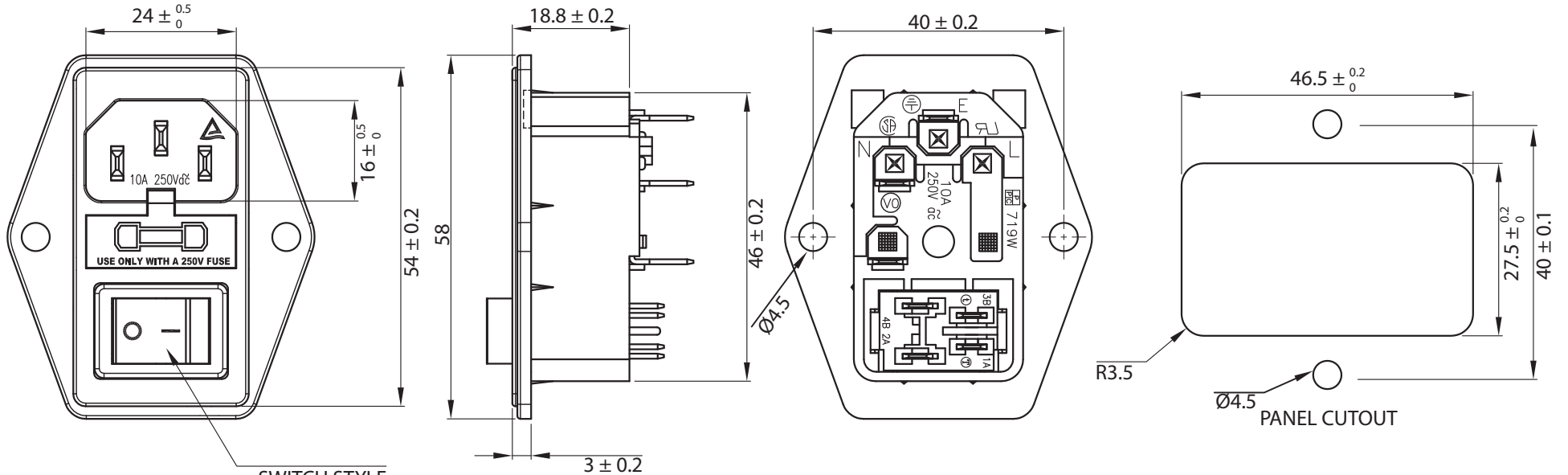

Part No.	marking Style	Body Color	Switch Button Color	Lamp Type	Rating
719W-UEL3BB81		Black	Black	no	10A
719W-UEL3BR51		Black	Red	110V/220V	10A
719W-UEL3BR81		Black	Red	no	10A
719W-UEL8BB81		Black	Black	no	10A
719W-UEL9BB81		Black	Black	no	10A

NOTES:

SOCKET:

RATING:

UL, CSA, TUV, CCC: 10A 250V AC

SWITCH:

RATING:

UL, cUL: 10GP/250V AC 50/60Hz T85

TV-5/125V AC 50/60Hz T85

ENEC, CQC, KTL: 8A/80A 250V AC 1E4 T85

10(4)A 250V AC 1E4 T85

RECOMMENDED FUSE SIZE: 5x20mm

FUSES NOT INCLUDED

RoHS COMPLIANT

**CONTROLLED**

Dim range (mm)	Tolerance +/- (mm)	Qualtek Electronics Corp. PPC DIVISION		
		Part Number:	719W-UEL	
0-1	0.30	Description: AC RECEPTACLE		
1-6	0.35			
6-18	0.40	UNIT: mm		
18-50	0.50			
50-120	0.70	Drawn / Date	Checked / Date	Approved / Date
120-250	0.90	R. Nuti 02-28-24	02-28-24	LY / 02-28-24
250-500	1.20			