

THESE DRAWINGS ARE THE PROPERTY OF QUALTEK ELECTRONICS AND NOT TO BE REPRODUCED FOR OR COMMUNICATED TO A THIRD PARTY WITHOUT THE EXPRESS WRITTEN PERMISSION OF AN OFFICER OF QUALTEK ELECTRONICS.

REVISION			
REV.	DESCRIPTION	DATE	APPROVED

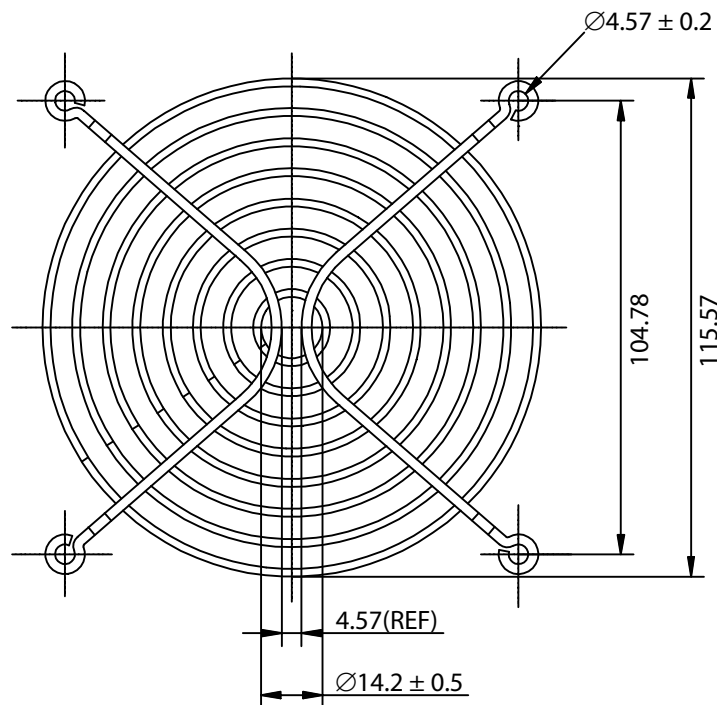

NOTES:

1. MATERIAL: STAINLESS STEEL WIRE
2. FINISH: ELECTROLYZE
3. 0.35 ± 0.05 DEPTH OF SERRATIONS ON WIRE
4. RING:  $\varnothing 1.8 \pm 0.1\text{mm}$   
RIB:  $\varnothing 2.3 \pm 0.1\text{mm}$
5. GENERAL TOLERANCE UNLESS NOTED IS  $\pm 0.5\text{mm}$
6. RoHS COMPLIANT

**CONTROLLED**

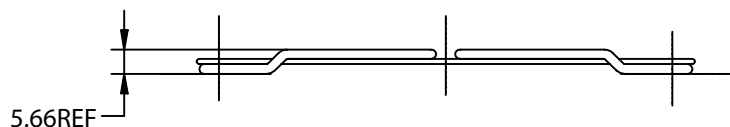

Dim range (mm)	Tolerance +/- (mm)	Qualtek Electronics Corp. FAN-S DIVISION		
		Part Number:	RoHS Compliant	
0-5	0.1	08130-SS	WIRE FORM FAN GUARD (120mm)	
5-16	0.15			
16-64	0.2		UNIT: mm	
64-250	0.4			
250-1000	0.5	Drawn / Date	Checked / Date	Approved / Date
1000-1500	1.0	R.Nuti 10-21-08	10-21-08	LY / 10-21-08